

VIAVAC GBXL CURVED

CURVED GLASS LIFTING AND PLACING UP TO 700 KG

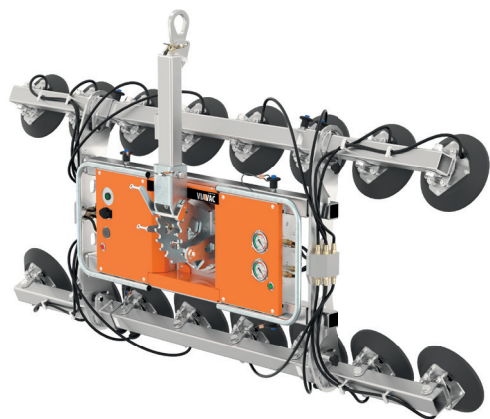

VACUUM GLASS LIFTER



VIAVAC GBXL CURVED

GLASS LIFTING AND PLACING UP TO 700 KG

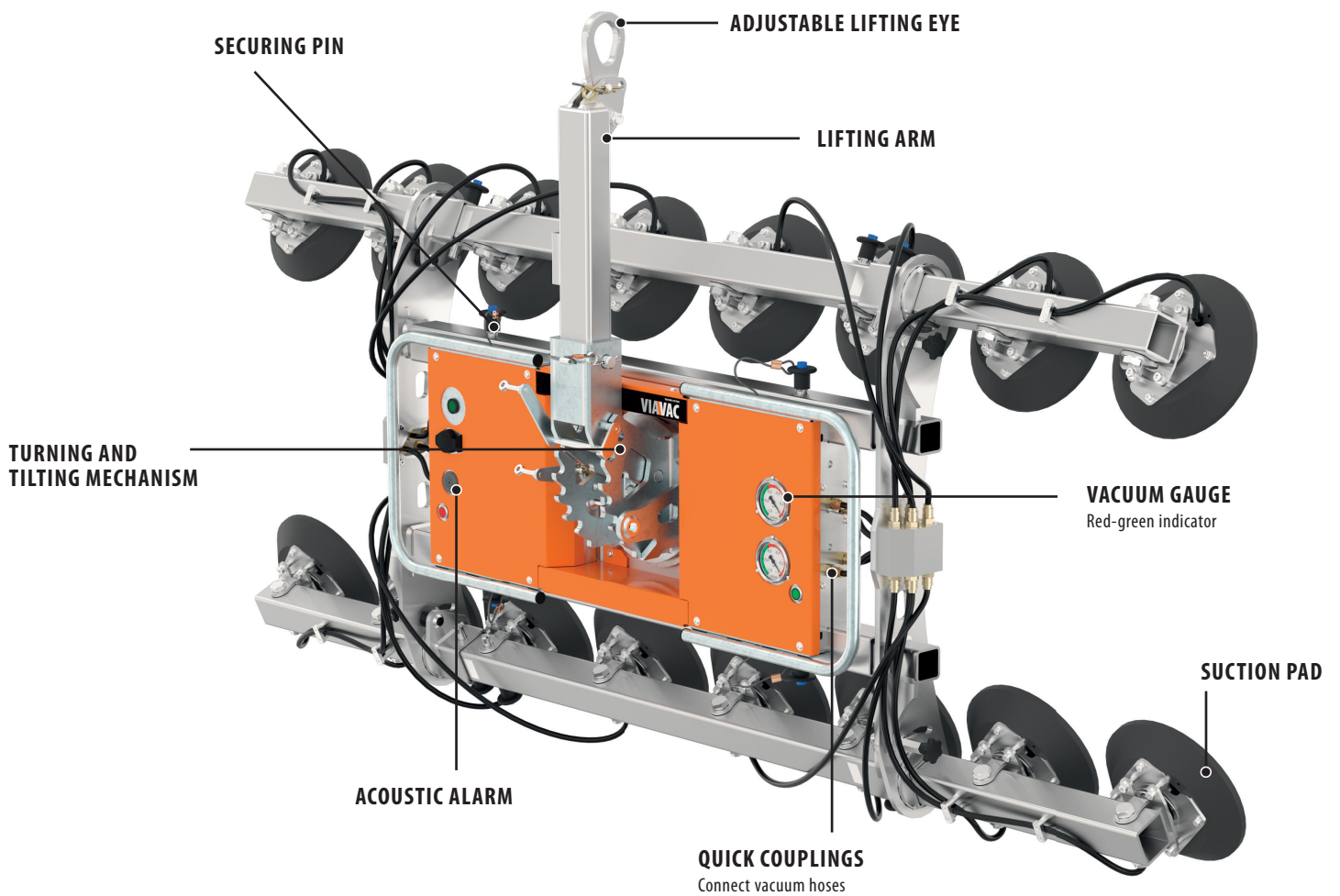

RADIO REMOTE CONTROL
Optional



MONTORIZED TILTING MECHANISM
Optional

FUNCTIONS

- 90° tilting mechanism with locking facility every 18°
- 360° rotation with locking facility in 4 positions
- Suitable for a radius of at least 800 mm
- Motorized tilting mechanism for even faster installation (optional)
- Radio remote control for suction & release (optional)

SAFETY FEATURES

- 2 independent vacuum circuits for double safety
- Integrated vacuum gauges with red / green indication
- Audible and visible low vacuum warning
- Low-battery warning
- Vacuum buffer tanks with non-return valves

SPECIFICATIONS

Configuration	GBXL-350/R800	GBXL-700/R800
Lifting capacity	350 kg	700 kg
Machine weight	120 kg	150 kg

Complies with European standard EN 13155

GBXL-350/R800
350 kg

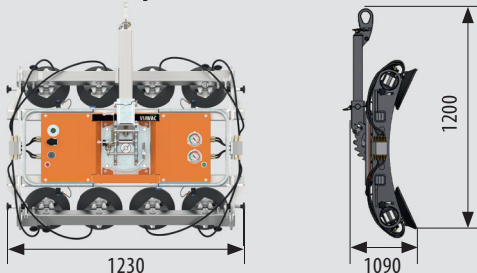

GBXL-700/R800
700 kg

